



OnLevel Test Report

TL-6000 Balustrade Testing to BS 6180: 2011

ONLEVEL

DOCUMENT REFERENCE: DR-5220
PROJECT FILE REFERENCE: P10002

Prepared for: OnLevel
18 Church Street, Ashton under Lyne, Lancashire, OL6 6XE

| Revision | Date | Reason for Issue: |
|----------|------------|---------------------------|
| Rev0 | 31/10/2019 | Draft for External Review |
| Rev1 | 26/11/2019 | Amended, Final Issue |
| | | |





CONTENTS

| | |
|-------------------------|---|
| 1. INTRODUCTION | 3 |
| 2. TEST SAMPLES..... | 3 |
| 3. TEST PROGRAMME | 4 |
| 4. TEST METHOD | 5 |
| 5. RESULTS | 6 |

APPENDIX:

- A OnLevel Balustrade Drawings
- B Test Certificates



1. INTRODUCTION

STS-UK Group were commissioned by Onlevel to undertake a series of balustrade tests on their own products in accordance with BS 6180:2011. Static load testing was carried out as described in the aforementioned standard to determine the load characteristics of the products. All testing was carried out by STS-UK Group at their Ellesmere Port Testing facility. The purpose of the testing was to attain results and findings that could be analysed to see if the systems were capable of withstanding the imposed loadings described in BS 6180:2011.

Installation of the barriers were carried out by STS-UK Group with On Level's own personnel overseeing the install.

The testing took place at the following address:

Site Address: STS-UK Group, Unit 4 Poole Hall Business Park, Poole Hall Road, Ellesmere Port, Cheshire, CH66 1UA

This report summarises the test results obtained during testing by STS-UK Group and does not provide any interpretation of those results.

2. TEST SAMPLES

The test samples were all provided by Onlevel and including all balustrade equipment and fixings. Each balustrade was fixed to a concrete section for testing. The concrete section was cast indoors and with a C60 grade concrete.

The samples provided were as follows:

- TL-6000 – various sizes

See Appendix A for Test Sample Drawings.

3. TEST PROGRAMME

The results tabulated below were found during testing between the 5th and 6th June 2019. For further analysis on the results found see section 4 of this report.

| Test Item | System Size (mm) | Glass (mm) | Notes/Comments |
|-----------|------------------|------------|----------------|
| TL-6000 | 1000 x 1200 | 10-1.52-10 | |
| TL-6000 | 1000 x 1200 | 8-1.52-8 | |
| TL-6000 | 1000 x 1200 | 6-1.5-6 | |

Table 1 – Test Programme

4. TEST METHOD

All balustrade testing was undertaken, as per BS 6180, by three separate methods. Firstly, a UDL (Uniformly Distributed Load) over the width of an individual panel, secondly an infill load over a m² section and finally a point load of 20mm² placed on the infill panel. The loads required for the standard varied from 0.36kN/m up to 3.0kN/m, depending on the client's request, the load is referenced in BS 6180:2011.

Following the installation of the balustrade by an OnLevel representative, the system was reviewed by and STS-UK technician. Following this a bespoke load frame was positioned in front of the balustrade and fixed down to the concrete floor.

The load frame held one hydraulic cylinder that was connected to a hand pump by way of hydraulic hoses and an in-line hydraulic pressure sensor. Once the frame and hydraulics were positioned, a draw wire displacement sensor was placed along the balustrade on a free-standing tripod as close to the hydraulic jack positions as possible and wired back to a logging system. The load was then applied in a steady manner, all displacement and forces were then dynamically recorded directly to a data logger. Once the test achieved its criteria, all imposed load was removed, and the permanent deflection noted down.

The tests were deemed a success if the system's (1) demonstrated they did not suffer non-elastic displacements and (2) displacements did not exceed 25mm respectively to their individual criteria, in accordance with BS 6180. If non-elastic displacements do occur the test was aborted, and the system declared unfit for purpose.

5. RESULTS

All Testing found in this report was carried out in accordance with guidance found in BS 6180:2011. This standard states that the maximum allowable deflection at full load is 25mm.

Table 2 below shows the results found during the testing, for test certificates please see Appendix B.

| Test Number | Product Type – Size - Glass | Date Tested | Test Type (UDL, Infill, Point load) | Load Applied | Result at Full Load (mm) | Pass/Fail |
|-------------|------------------------------------|---------------------------|-------------------------------------|----------------------|--------------------------|-----------|
| 5 | TL-6000 – 1200 x 1100 – 10-1.52-10 | 3 rd July 2019 | UDL | 0.74kN/m | 20.35 | Pass |
| 6 | TL-6000 – 1200 x 1100 – 10-1.52-10 | 3 rd July 2019 | Point Load | 0.5kN | 5.73 | Pass |
| 7 | TL-6000 – 1200 x 1100 - 10-1.52-10 | 3 rd July 2019 | Infill | 1.0kN/m ² | 10.22 | Pass |
| 9 | TL-6000 – 1200 x 1100 - 8-1.52-8 | 3 rd July 2019 | UDL | 0.74kN/m | 24.78 | Pass |
| 10 | TL-6000 – 1200 x 1100 - 8-1.52-8 | 3 rd July 2019 | Point Load | 0.5kN | 21.11 | Pass |
| 11 | TL-6000 – 1200 x 1100 - 8-1.52-8 | 3 rd July 2019 | Infill | 1.0kN/m ² | 14.33 | Pass |
| 12 | TL-6000 – 1200 x 1100 – 6-1.5-6 | 3 rd July 2019 | UDL | 0.36kN/m | 18.46 | Pass |
| 13 | TL-6000 – 1200 x 1100 – 6-1.5-6 | 3 rd July 2019 | Point Load | 0.25kN | 12.51 | Pass |
| 14 | TL-6000 – 1200 x 1100 – 6-1.5-6 | 3 rd July 2019 | Infill | 0.5kN/m ² | 10.06 | Pass |

Table 3 – Product Test Results

All Information found in this report is formed from factual results found during the testing of the products.

For photographic records of sample testing please see Appendix C.

| | Name | Signature | Date |
|---|-------------|-----------|------------|
| Created By: Technical Director | Andrew Gore | | 26.11.2019 |
| Checked By: Commercial Director | Ryan Kundi | | 26.11.2019 |

For and on behalf of Specialist Technical Services (U.K) Limited



APPENDIX A

OnLevel Balustrade Drawings

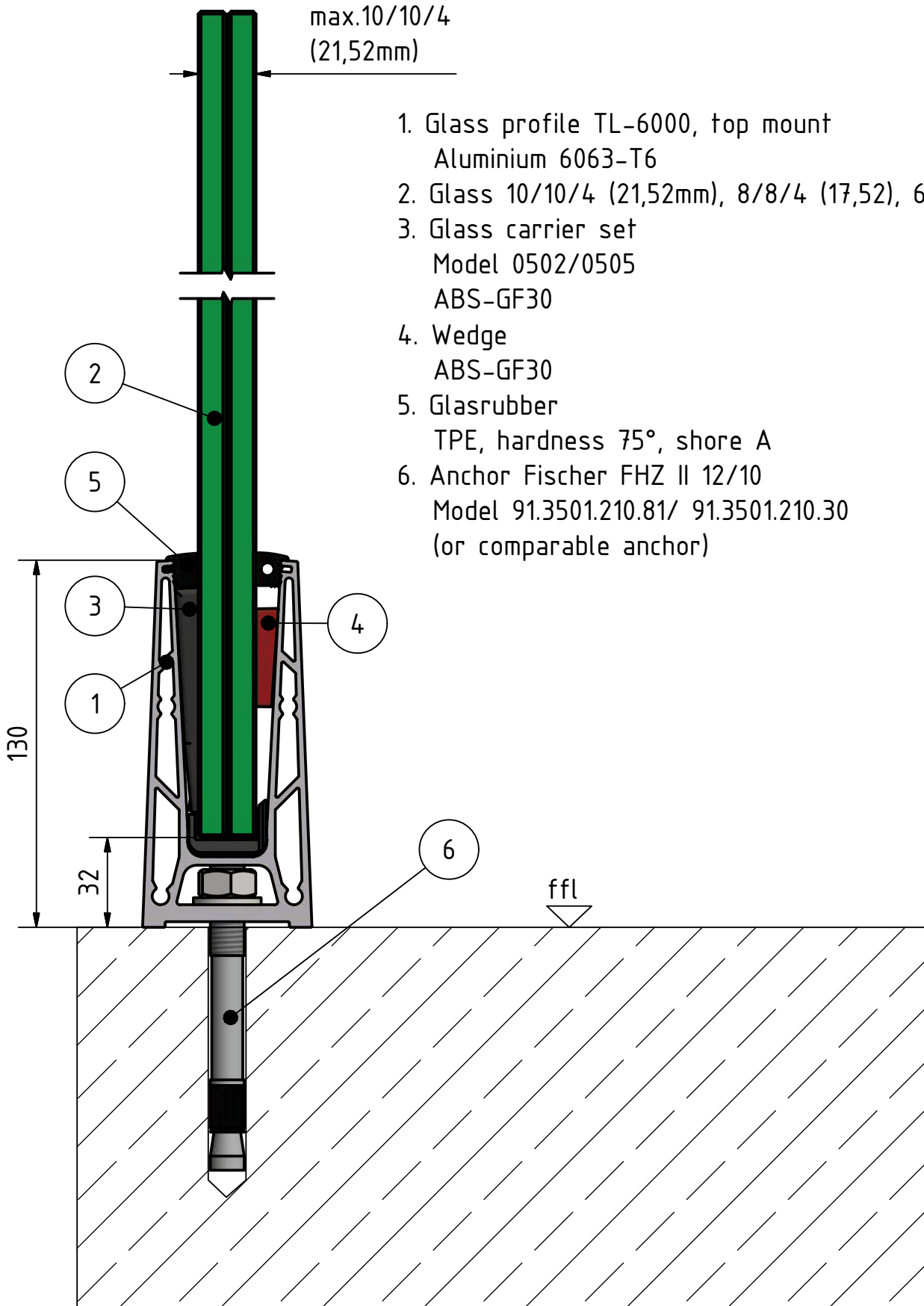

max.10/10/4
(21,52mm)

1. Glass profile TL-6000, top mount
Aluminium 6063-T6
2. Glass 10/10/4 (21,52mm), 8/8/4 (17,52), 6/6/4 (12,76)
3. Glass carrier set
Model 0502/0505
ABS-GF30
4. Wedge
ABS-GF30
5. Glasrubber
TPE, hardness 75°, shore A
6. Anchor Fischer FHZ II 12/10
Model 91.3501.210.81/ 91.3501.210.30
(or comparable anchor)

130

32

ffl

| | | | |
|---|----------------------|---------------------------------------|------------|
| Designed by FV | Created 30-9-2019 | Modified | Comment |
|  | | Description Detail:Figure 1 | |
| | | Article number TL-6000 (top mount) | Size A4 |

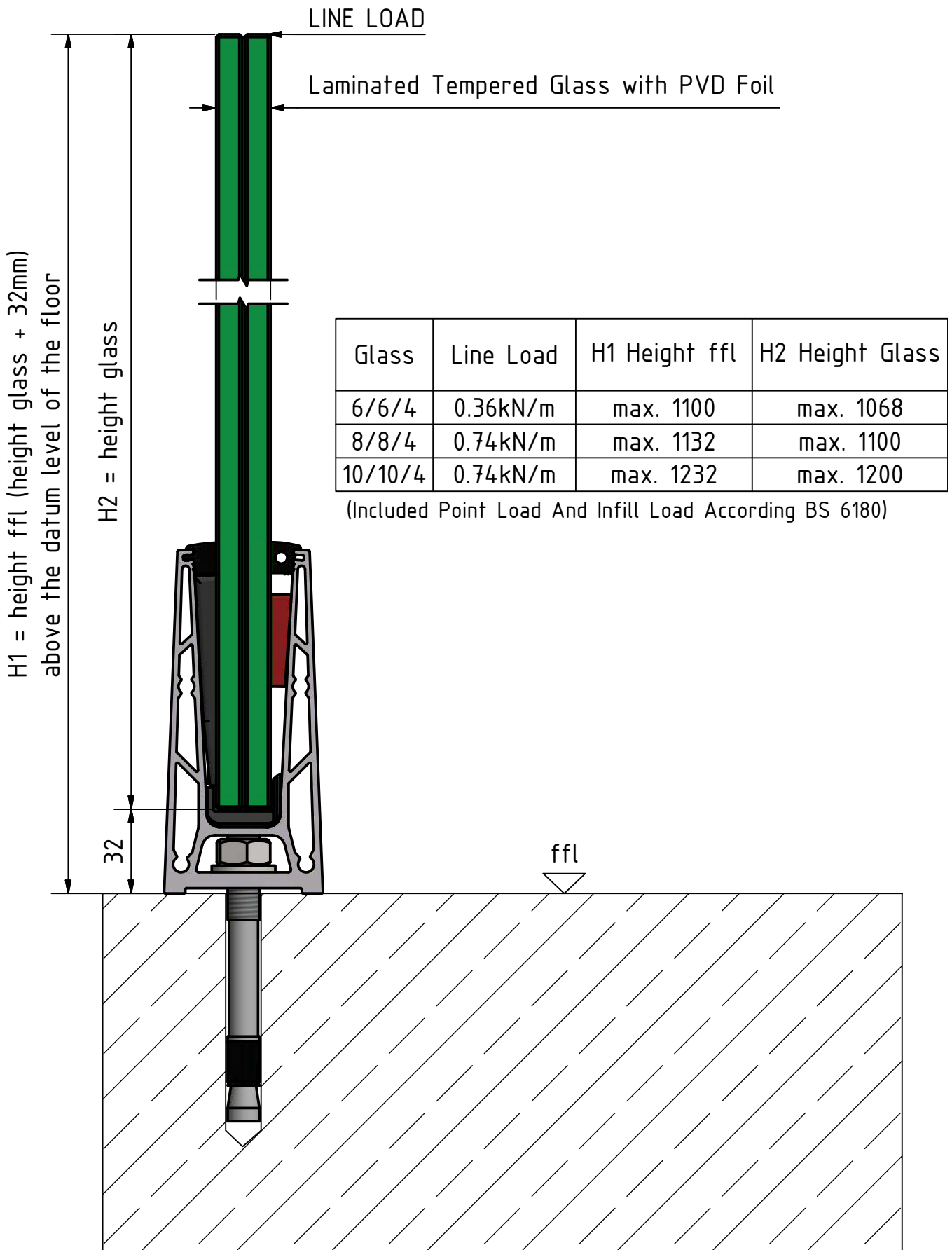

| | | | |
|---|----------------------|---|------------|
| Designed by FV | Created 30-9-2019 | Modified | Comment |
|  | | Description Detail: Figure 2 (Line Load / Glass Heights) | |
| | | Article number TL-6000 (top mount) | Size A4 |

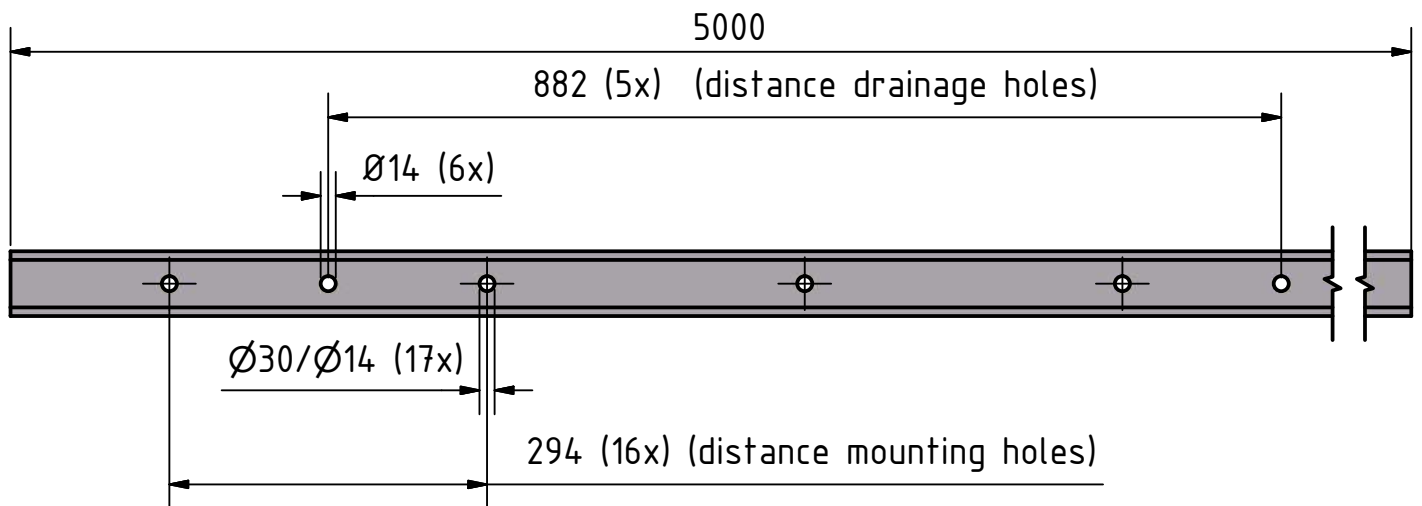
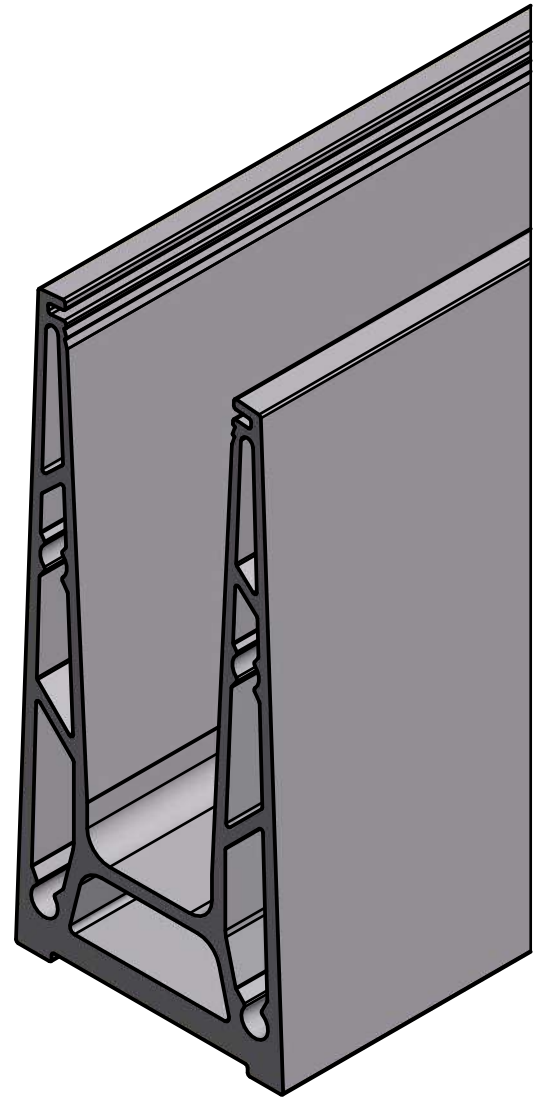
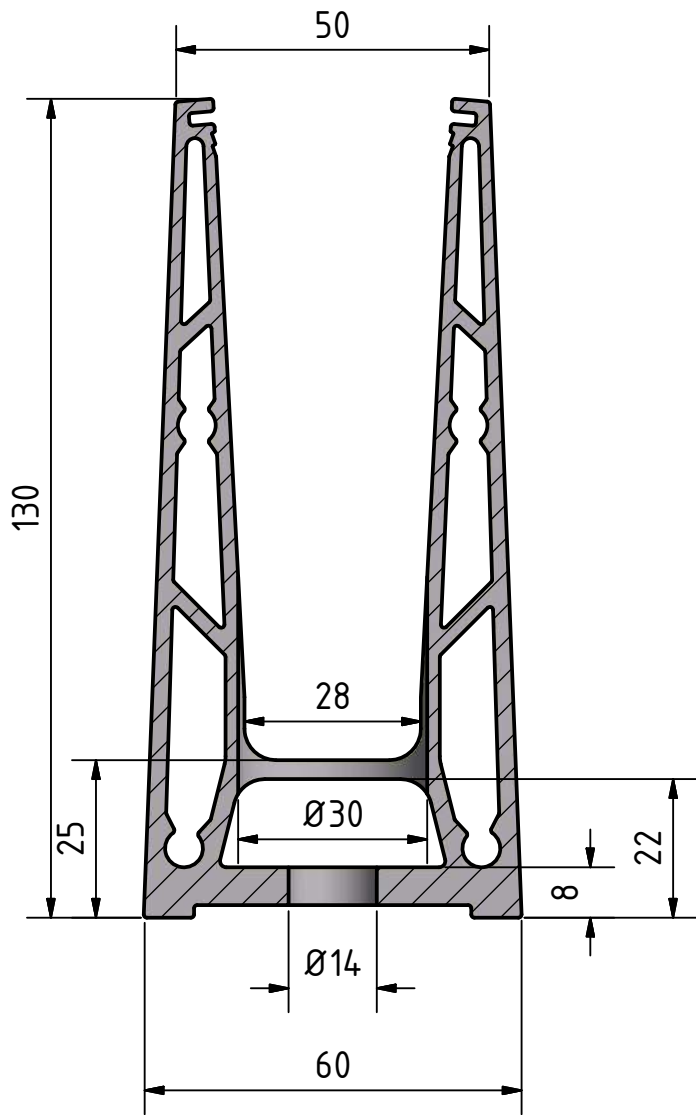

Material: Aluminum 6063-T6

| | | | |
|---|----------------------|---|------------|
| Designed by FV | Created 30-9-2019 | Modified | Comment |
|  | | Description Profile TL-6000 L=5000mm | |
| | | Article number TL-6000 (top mount) | Size A4 |

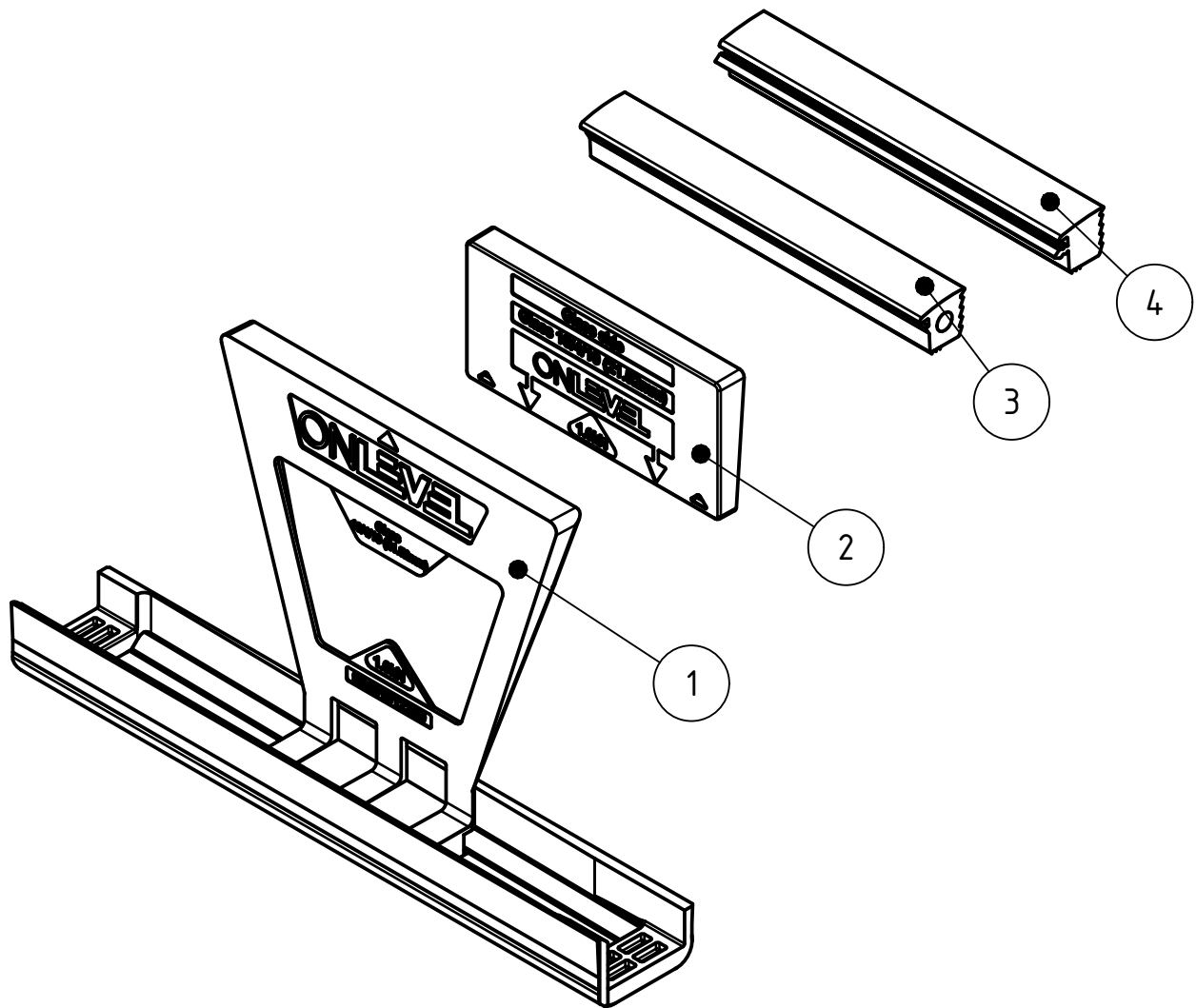

| ITEM | PCS (L=2500mm) | PCS (L=5000mm) | Description |
|------|----------------|----------------|---------------------|
| 1 | 8 | 16 | Flex-Fit 1.0KN |
| 2 | 8 | 16 | Glass Wedge 1.0KN |
| 3 | 1 (L=2500mm) | 1 (L=5000mm) | Rubber User Side |
| 4 | 1 (L=2500mm) | 1 (L=5000mm) | Rubber Falling Side |

Distance Glass Carrier
/ Glass Wedges :

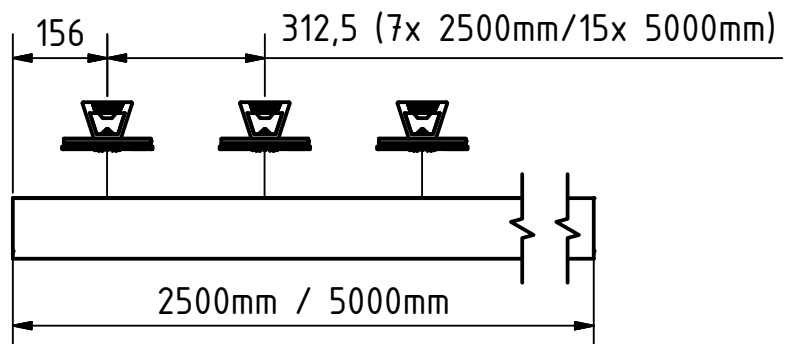

| | | | |
|---|----------------------|---|------------|
| Designed by FV | Created 30-9-2019 | Modified | Comment |
|  | | Description Flex-Fits sets (quantity and distance) | |
| | | Article number TL-6000 (top mount) | Size A4 |



APPENDIX B

Test Certificates



TEST CERTIFICATE
BALUSTRADE TESTING IN ACCORDANCE WITH BS 6180:2011

On behalf of OnLevel Ltd
8 Alexandria Court, Ashton Commerce Park, Ashton Commerce Park,
Ashton-under-Lyne, Lancashire, OL7 0QN, United Kingdom

HORIZONTAL UDL 0.74kN,
TL-6000 BARRIER

TEST DESCRIPTION: A uniformly distributed load was applied to the balustrade system at a height of 1100mm to determine the deflection of the balustrade system when assembled. Independent drawstring potentiometers were positioned accordingly to measure the deflection of the installed system throughout the testing procedure. The balustrade system was installed by the client to their own specification.

REF NO.: DR-5204 **DATE TESTED:** 03rd July 2019
JOB NO.: P10002 **DATE REPORTED:** N / A
CERTIFICATE NO.: IC8591 **CERTIFICATE DATE:** 17th July 2019
TEST DETAILS:

Barrier Test Height: 1200mm
Barrier Test Length: 1000mm
Test Description: Test 5 – 0.74kN UDL – TL-6000
TEST RESULTS:

| Load (kN/m) | Displacement (mm) | Permanent Displacement (mm) |
|-------------|-------------------|-----------------------------|
| 0.74kN | 20.35 | 2.38 |

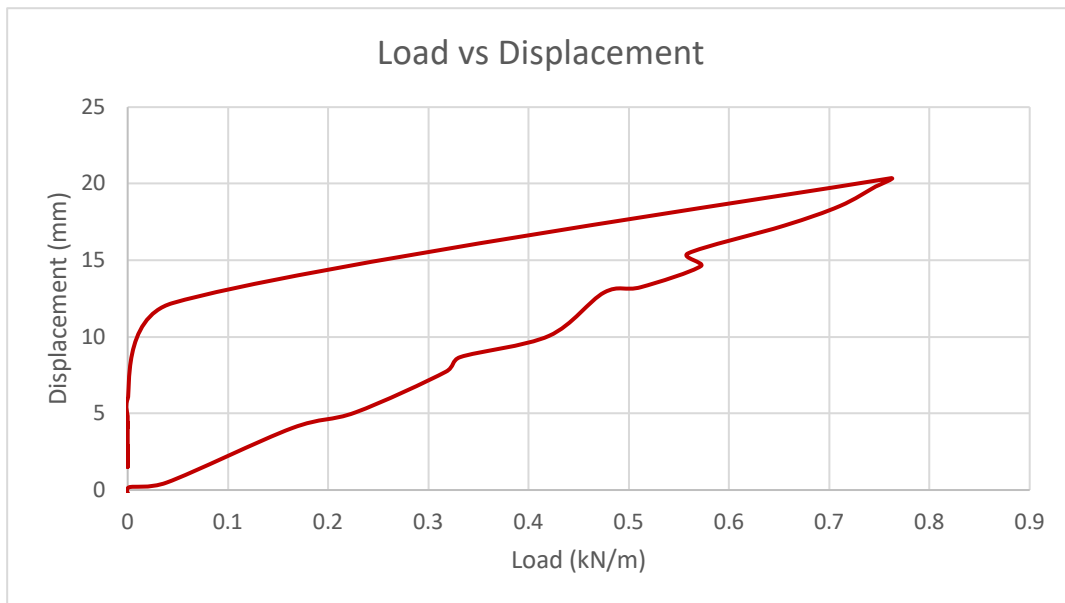

ANALYSIS:
The balustrade system when assembled and tested in the manor indicated within this certificate conforms to BS6180:2011. The balustrade barrier achieved a loading of 0.74kN/m with a maximum recorded displacement of 20.35mm.

NAME: Evan Wiggins
POSITION: Junior Technician



TEST CERTIFICATE
BALUSTRADE TESTING IN ACCORDANCE WITH BS 6180:2011

On behalf of OnLevel Ltd
8 Alexandria Court, Ashton Commerce Park, Ashton Commerce Park,
Ashton-under-Lyne, Lancashire, OL7 0QN, United Kingdom

Infill UDL 1kN,
TL-6000 BARRIER

TEST DESCRIPTION: An Infill UDL was applied to the balustrade system using a large, square spreader reacting on the glass pane to determine the deflection of the balustrade system when assembled. Independent drawstring potentiometers were positioned accordingly to measure the deflection of the installed system throughout the testing procedure. The balustrade system was installed by the client to their own specification.

| | | | |
|-------------------------|---------|--------------------------|----------------------------|
| REF NO.: | DR-5204 | DATE TESTED: | 03 rd July 2019 |
| JOB NO.: | P10002 | DATE REPORTED: | N / A |
| CERTIFICATE NO.: | IC8593 | CERTIFICATE DATE: | 17 th July 2019 |

TEST DETAILS:
Barrier Test Height: 1200mm
Barrier Test Length: 1000mm
Test Description: Test 7 – 1kN Infill UDL – TL-6000

| Load (kN/m) | Displacement (mm) | Permanent Displacement (mm) |
|-------------|-------------------|-----------------------------|
| 1kN | 10.22 | 0.56 |

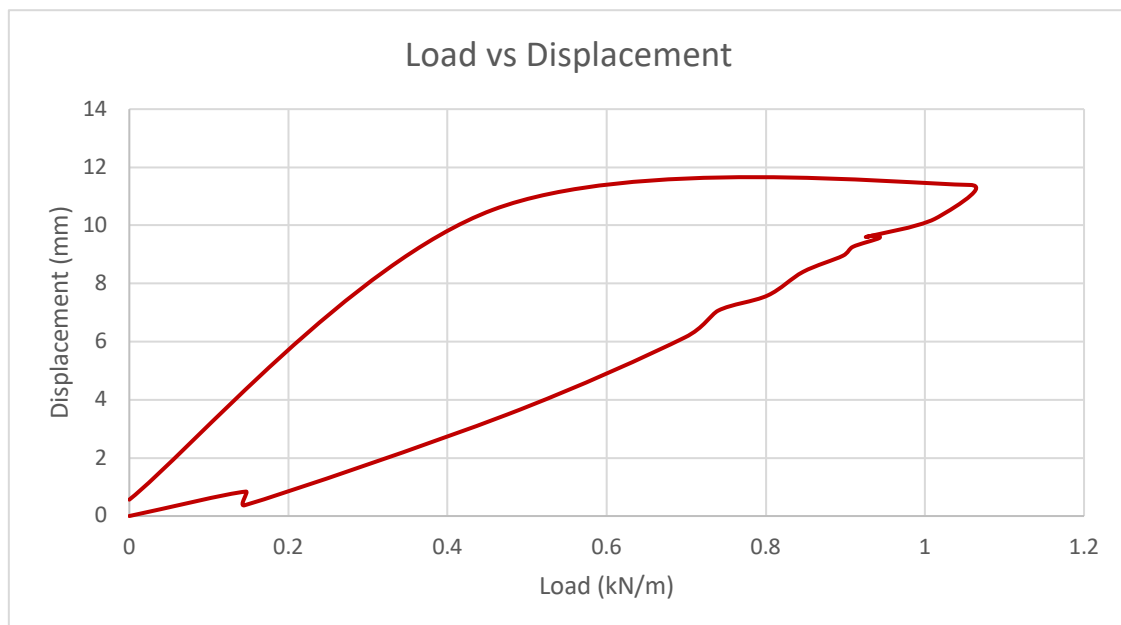

ANALYSIS:

The balustrade system when assembled and tested in the manor indicated within this certificate conforms to BS6180:2011. The balustrade barrier achieved a loading of 1kN/m with a maximum recorded displacement of 10.22mm.

NAME: Evan Wiggins
POSITION: Junior Technician



TEST CERTIFICATE
BALUSTRADE TESTING IN ACCORDANCE WITH BS 6180:2011

On behalf of OnLevel Ltd
8 Alexandria Court, Ashton Commerce Park, Ashton Commerce Park,
Ashton-under-Lyne, Lancashire, OL7 0QN, United Kingdom

HORIZONTAL UDL 0.74kN,
TL-6000 BARRIER

TEST DESCRIPTION: A uniformly distributed load was applied to the balustrade system at a height of 1100mm to determine the deflection of the balustrade system when assembled. Independent drawstring potentiometers were positioned accordingly to measure the deflection of the installed system throughout the testing procedure. The balustrade system was installed by the client to their own specification.

REF NO.: DR-5204 **DATE TESTED:** 03rd July 2019
JOB NO.: P10002 **DATE REPORTED:** N / A
CERTIFICATE NO.: IC8595 **CERTIFICATE DATE:** 22nd July 2019
TEST DETAILS:

Barrier Test Height: 1200mm
Barrier Test Length: 1000mm
Test Description: Test 9 – 0.74kN UDL – TL-6000 – 8mm Glass – 4 glass packers
TEST RESULTS:

| Load (kN/m) | Displacement (mm) | Permanent Displacement (mm) |
|-------------|-------------------|-----------------------------|
| 0.74kN | 24.78 | 0.97 |

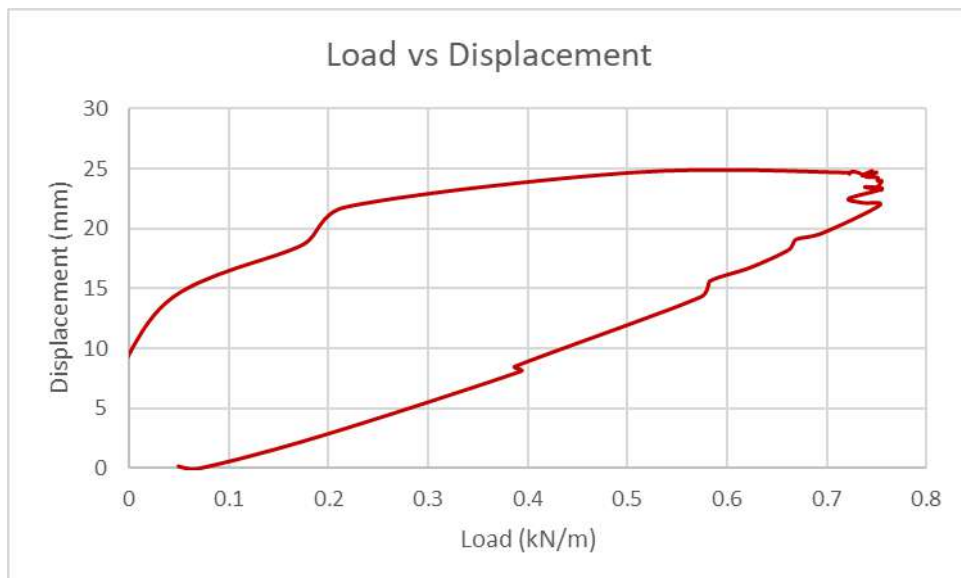

ANALYSIS:
The balustrade system when assembled and tested in the manor indicated within this certificate conforms to BS6180:2011. The balustrade barrier achieved a loading of 0.74kN/m with a maximum recorded displacement of 24.78mm.

NAME: Evan Wiggins
POSITION: Junior Technician



TEST CERTIFICATE
BALUSTRADE TESTING IN ACCORDANCE WITH BS 6180:2011

On behalf of OnLevel Ltd
8 Alexandria Court, Ashton Commerce Park, Ashton Commerce Park,
Ashton-under-Lyne, Lancashire, OL7 0QN, United Kingdom

Infill UDL 1kN,
TL-6000 BARRIER

TEST DESCRIPTION: An Infill UDL was applied to the balustrade system using a large, square spreader reacting on the glass pane to determine the deflection of the balustrade system when assembled. Independent drawstring potentiometers were positioned accordingly to measure the deflection of the installed system throughout the testing procedure. The balustrade system was installed by the client to their own specification.

REF NO.: DR-5204 **DATE TESTED:** 03rd July 2019
JOB NO.: P10002 **DATE REPORTED:** N / A
CERTIFICATE NO.: IC8597 **CERTIFICATE DATE:** 22nd July 2019
TEST DETAILS:

Barrier Test Height: 1200mm
Barrier Test Length: 1000mm
Test Description: Test 11 - 8mm Glass - TL-6000 - 1kN - 4 packers

TEST RESULTS:

| Load (kN/m) | Displacement (mm) | Permanent Displacement (mm) |
|-------------|-------------------|-----------------------------|
| 1kN | 14.33 | 0.26 |

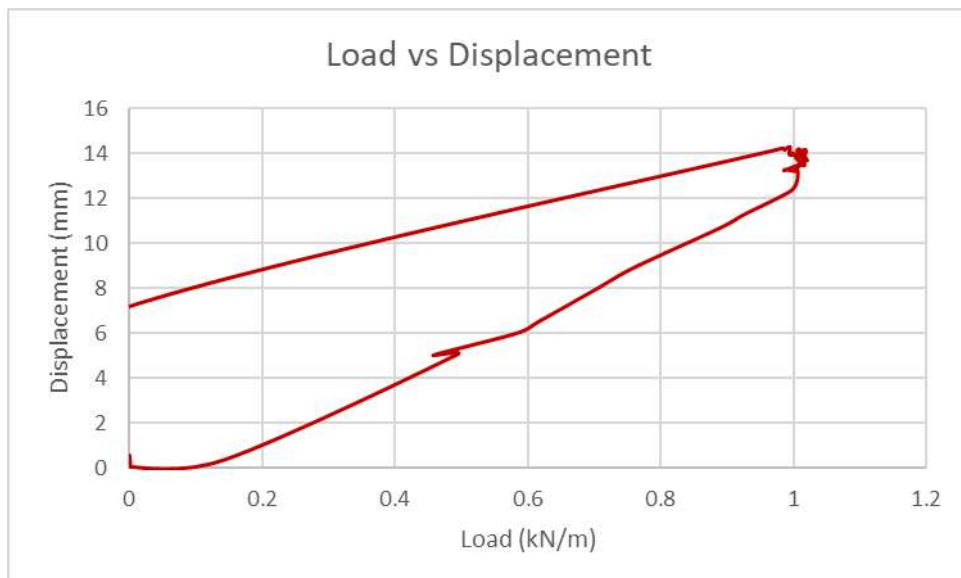

ANALYSIS:

The balustrade system when assembled and tested in the manor indicated within this certificate conforms to BS6180:2011. The balustrade barrier achieved a loading of 1kN/m with a maximum recorded displacement of 14.33mm.

NAME: Evan Wiggins
POSITION: Junior Technician



TEST CERTIFICATE
BALUSTRADE TESTING IN ACCORDANCE WITH BS 6180:2011

On behalf of OnLevel Ltd
8 Alexandria Court, Ashton Commerce Park, Ashton Commerce Park,
Ashton-under-Lyne, Lancashire, OL7 0QN, United Kingdom

HORIZONTAL UDL 0.36kN,
TL-6000 BARRIER

TEST DESCRIPTION: A uniformly distributed load was applied to the balustrade system at a height of 1100mm to determine the deflection of the balustrade system when assembled. Independent drawstring potentiometers were positioned accordingly to measure the deflection of the installed system throughout the testing procedure. The balustrade system was installed by the client to their own specification.

REF NO.: DR-5204 **DATE TESTED:** 03rd July 2019
JOB NO.: P10002 **DATE REPORTED:** N / A
CERTIFICATE NO.: IC8598 **CERTIFICATE DATE:** 22nd July 2019
TEST DETAILS:

Barrier Test Height: 1200mm
Barrier Test Length: 1000mm
Test Description: Test 12 - TL-6000 – 6mm x 1.5mm x 6mm GLASS - 0.36kN
TEST RESULTS:

| Load (kN/m) | Displacement (mm) | Permanent Displacement (mm) |
|-------------|-------------------|-----------------------------|
| 0.36kN | 18.46 | 0.95 |

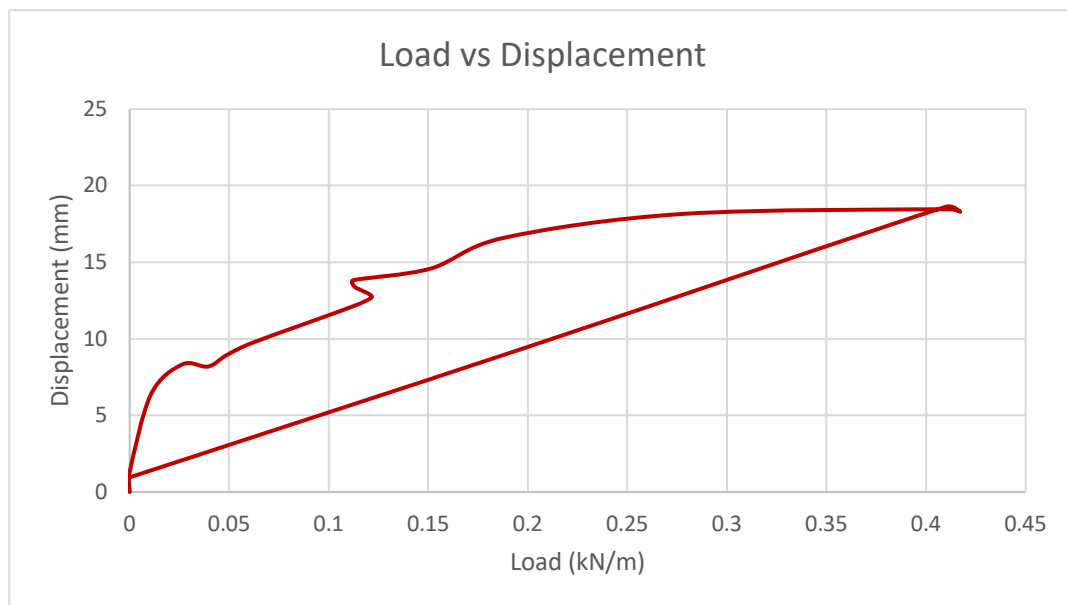

ANALYSIS:
The balustrade system when assembled and tested in the manner indicated within this certificate conforms to BS6180:2011. The balustrade barrier achieved a loading of 0.36kN/m with a maximum recorded displacement of 18.46mm.

NAME: Evan Wiggins
POSITION: Junior Technician



TEST CERTIFICATE
BALUSTRADE TESTING IN ACCORDANCE WITH BS 6180:2011

On behalf of OnLevel Ltd
8 Alexandria Court, Ashton Commerce Park, Ashton Commerce Park,
Ashton-under-Lyne, Lancashire, OL7 0QN, United Kingdom

Infill UDL 0.5kN,
TL-6000 BARRIER

TEST DESCRIPTION: An Infill UDL was applied to the balustrade system using a large, square spreader reacting on the glass pane to determine the deflection of the balustrade system when assembled. Independent drawstring potentiometers were positioned accordingly to measure the deflection of the installed system throughout the testing procedure. The balustrade system was installed by the client to their own specification.

REF NO.: DR-5204 **DATE TESTED:** 03rd July 2019
JOB NO.: P10002 **DATE REPORTED:** N / A
CERTIFICATE NO.: IC8600 **CERTIFICATE DATE:** 22nd July 2019
TEST DETAILS:

Barrier Test Height: 1200mm
Barrier Test Length: 1000mm
Test Description: Test 14 - TL-6000 – 6mm x 1.5mm x 6mm GLASS - 0.5kN

TEST RESULTS:

| Load (kN/m) | Displacement (mm) | Permanent Displacement (mm) |
|-------------|-------------------|-----------------------------|
| 0.5kN | 10.06 | 1.05 |

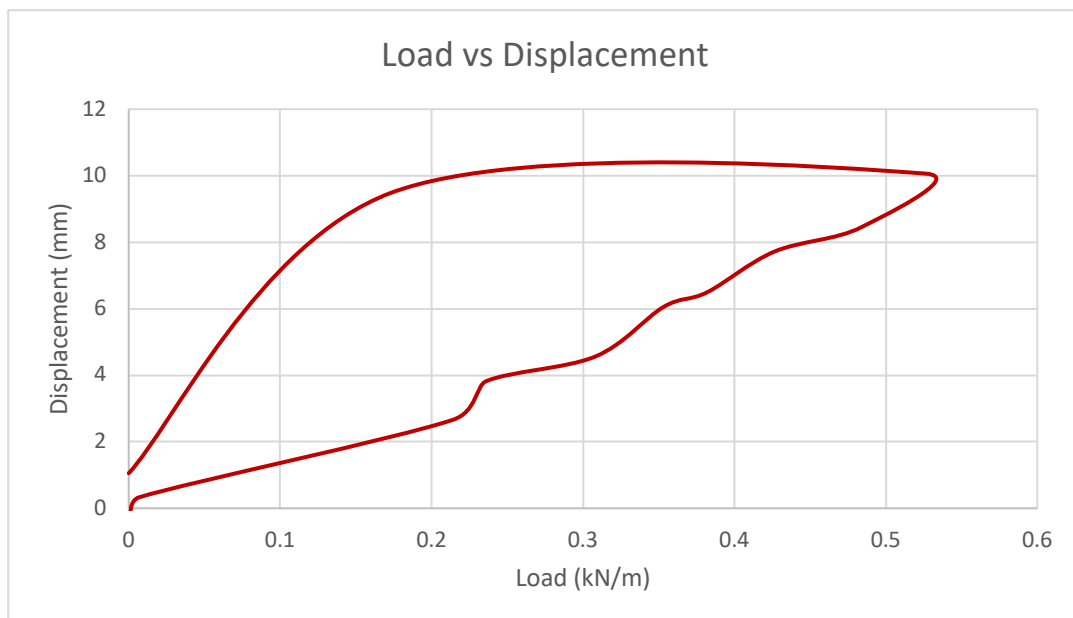

ANALYSIS:

The balustrade system when assembled and tested in the manor indicated within this certificate conforms to BS6180:2011. The balustrade barrier achieved a loading of 0.5kN/m with a maximum recorded displacement of 10.06mm.

NAME: Evan Wiggins
POSITION: Junior Technician